



HENDRIX
COLLEGE

Brand Guide

**A GUIDE TO THE HENDRIX BRAND
AND GRAPHIC IDENTITY SYSTEM**





HENDRIX
COLLEGE

BRAND GUIDE

This Hendrix College Brand Guide provides easy-to-follow guidelines to help Hendrix faculty, staff, and associates maintain the College's visual identity and brand standards as they communicate with internal and external audiences on behalf of Hendrix.

Use of these standards by everyone involved in Hendrix Communications activities preserves the integrity of the College's graphic identity and ensures that the Hendrix brand is presented accurately, clearly, and consistently.

Vendors hired by all areas of the College to produce printed, digital, or specialty materials for Hendrix are expected to follow the visual identity and brand standards included in this guide. The College may refuse payment for any material not meeting graphic identity standards.

Direct any questions about brand and graphic identity standards to the Communications staff. For assistance with any task involving the College's graphic identity standards, use the Project Request Form: www.hendrix.edu/marcom/projectrequestform.

CONTACT:

Office of Communications
Amy Forbus, Communications Director
501-450-1462
forbus@hendrix.edu
www.hendrix.edu/communications

Additional resources may be found online at
www.hendrix.edu/brandguide.

Updated Fall 2023

CONTENTS

- 2 Logo
- 3 Colors
- 4 Alternative Logos
- 5 Special Programs
- 6 School-Leading Athletics Logo
- 7 Variations of Athletics Logo
- 8 Legibility of Athletics Logo
- 9 Colors
- 10 Symbol-Leading Athletics Logo
- 11 Variations of Athletics Logo
- 12 Legibility of Athletics Logo
- 13 Colors
- 14 Typefaces
- 15 Stationery
- 16 Interior Signs & Exterior Plaques
- 17 Exterior Signs
- 18 Interior/Exterior Informal Signage
- 19 FAQ

Our Logo

The basis of the Hendrix College graphic identity is the logo. The logo consists of two parts: the shield and the wordmark (fig. 1.1). Within the shield is the College's date of founding, 1876, and three Gothic arches reminiscent of the arches found in front of Staples Auditorium and Trieschmann Fine Arts Building. The wordmark is unique and has been specifically crafted; do not attempt to recreate it or any other part of the logo. Art may be obtained from the Office of Communications or online at www.hendrix.edu/brandguide.

APPROPRIATE USE

The Hendrix logo may only be used to identify the College's identity, its programs, and its services. The development and use of any other logo, mark, and/or symbol is strictly prohibited. The Hendrix logo may not be combined with any other feature — including, but not limited to, other logos, words, graphics, or symbols. The shape, proportion, or color of the Hendrix logo may not be changed in any way. The logo may not be redrawn or altered (See fig. 1.2).

To ensure legibility, the Hendrix logo should never be reproduced at sizes smaller than one inch wide. The Hendrix logo's proportions should never be altered. Do not condense or extend the logo (See fig. 1.3).

When in doubt about the appropriate use of the Hendrix logo, contact the Office of Communications for assistance.

CONTROL AREA

To be visually effective, the Hendrix logo requires an open area around it. This open area is called "the Control Area" in this manual. No other visual elements may appear in the Control Area. The Control Area is a border (margin) of empty space around the logo equal to the width of the letter H in the Hendrix wordmark.



In the figure above, a gray border the width of the "H" in "Hendrix" indicates the size of the Control Area around the logo. No words or images should be positioned closer to the logo than the Control Area's outer edge. An example of this can be found on page 6, when adding the College tagline.

fig. 1.1 - Logo elements

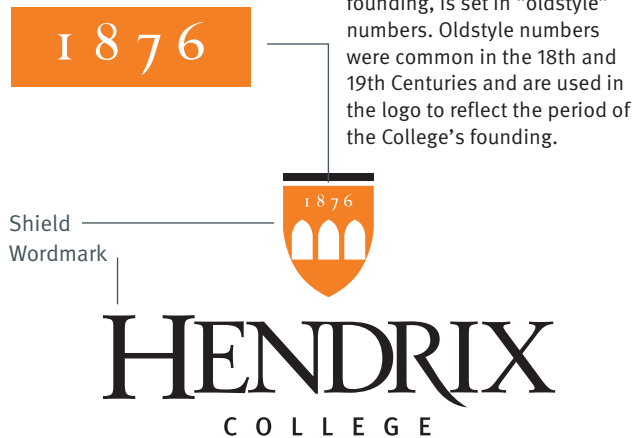

Date of Founding
1876, the year of Hendrix's founding, is set in "oldstyle" numbers. Oldstyle numbers were common in the 18th and 19th Centuries and are used in the logo to reflect the period of the College's founding.

fig. 1.2 - Recreating the logo



fig. 1.3 - Limitations on size and proportion



COLORS

PMS 158

Orange and black have been the Hendrix colors for more than a century. To create consistency, a specific orange has been selected for use as Hendrix Orange: PANTONE MATCHING SYSTEM® 158 (See fig. 2.1).

BLACK

WHITE

Since Hendrix Orange is an integral part of the Hendrix College graphic identity, it is important to have the logo appear in this color as often as possible. When the production method will not permit the use of the spot color, allowable alternatives are: A process color equivalent when printing in CMYK: 0, 61, 97, 0 (See fig. 2.2). RGB values of 245, 130, 42 when displaying Hendrix Orange digitally on screen (See fig. 2.3).

Separate files have been created for PMS, CMYK, Black, and White. These files may be obtained from the Office of Communications or online at www.hendrix.edu/brandguide.

1876 AND ARCHES

The 1876 should be white when presented on an orange shield or black shield, and black when presented on a white shield. The arches “knock-out” to reveal the color behind the logo.

SHIELD AND BAR

The bar and shield should only ever be black & orange, solid orange, solid black, or solid white, depending on the background. Black & orange is preferred wherever possible (fig. 2.4).

PRINTING IN BLACK AND WHITE

There may be instances when color is not an option, such as a newspaper advertisement or printing from a desktop laser printer. Black-and-white versions of the logo have been developed for use on these occasions.

Do not print the color version of the logo in black and white.

conspicuously
not orange



fig. 2.1 - spot colors for offset printing



fig. 2.2 - 4-color process colors for offset printing



fig. 2.3 - RGB process for screens & projectors



fig. 2.4 - Shield & Bar color variations



NOTE: The colors depicted on this page and throughout the Hendrix College Brand Guide are only representational of the actual PMS colors. Please refer to a PMS color guide for accurate color.

ALTERNATIVE LOGOS

The Hendrix College graphic identity is flexible. Variations of the logo have been created to fulfill almost any situation's needs. Contact the Office of Communications for assistance in determining when it's appropriate to use an alternative logo. Do not attempt to recreate any of these logos; art may be obtained from the Office of Communications or online at www.hendrix.edu/brandguide.



ALTERNATIVE 1: HENDRIX LOGO WITHOUT COLLEGE

To be used in situations where the production process cannot accurately reproduce College. To use this logo contact the Office of Communications.



ALTERNATIVE 2: HORIZONTAL LOGO

To be used in situations where vertical space is limited. Control space similar to the primary logo is recommended.



ALTERNATIVE 3: HENDRIX WORDMARK

To be used in situations where clarity or size is an issue.



ALTERNATIVE 4: HENDRIX SHIELD

The word "Hendrix" replaces the "1876." The shield is generally reserved for promotional items such as cups, tie tacks, clothing, or similar items. It is also used as part of the Special Programs logos.

LEGIBILITY

Clarity and readability are key to the overall strength of the Hendrix logo. The preferred color background for the Hendrix logo is white. Do not place the logo on colored or patterned backgrounds that impair the readability of the mark. Colored backgrounds are acceptable; however, it is important to use care in selecting the correct version of the logo to use in these situations (see **fig. 2.5**).

In situations where the logo is used on a color of similar value, the logo should be reversed (white) from the color. Or, if there is enough contrast, it can be printed in black.

Always take care in the placement of the logo and avoid busy or highly patterned backgrounds.

For assistance in selecting the appropriate version of the Hendrix logo to use, contact the Office of Communications.

fig. 2.5 - Coordinating logo and background



Photographs may be used behind the logo, though care should be taken to ensure the logo is free from clutter and is easy to read.

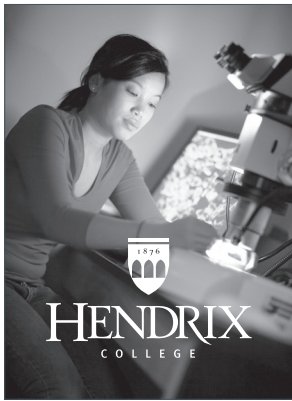
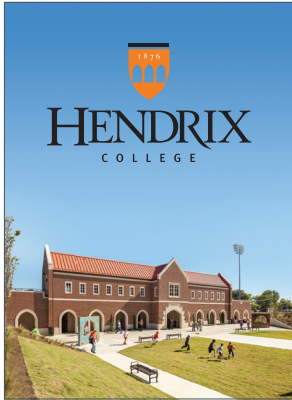

SPECIAL PROGRAMS

Programs and centers receiving outside funding or private grants and having an audience or mission that extends beyond the Hendrix community may use logos that are more visually distinct than images used by campus departments or offices. However, these special logos must maintain a strong visual association with the College. If your program fits this profile, please contact the Office of Communications. We will work closely with you to develop a graphic identity that meets your program needs and fits into the Hendrix family of images. Some examples appear below.



NOTE: The standards discussed in other sections of this guide apply to each of the special program and center identities.

DEPARTMENTAL AND OFFICE LOGOS

Departments and offices of the College are identified by small-caps text in the Meta OT Medium typeface underneath the Hendrix logo. The Office of Communications will provide individualized logo artwork for any department or office when requested. To request a departmental or office logo file, complete the form at www.hendrix.edu/marcom/projectrequestform.



THE SEAL

The Hendrix seal is reserved for official and ceremonial purposes only. The use of the seal must be approved by the Vice President of Communications. Once approved, art may only be obtained from the Office of Communications.

Athletics Logo

SCHOOL-LEADING

The Hendrix Warriors school-leading logo consists of two parts: the athletics shield and the Hendrix Warriors wordmark (fig. 3.1). Within the shield is the Hendrix H from the College logo.

The school-leading athletics logo — the Hendrix Warriors wordmark and the athletics shield (see figs. 3.1 and 3.2) — should not be used in place of the Hendrix shield or in coordination with the Hendrix College logo. They should serve as unique symbols for the College’s athletics teams. **Do not attempt to recreate or modify these logos; art may be obtained from the Office of Communications, the Department of Intercollegiate Athletics or online at www.hendrix.edu/brandguide.**

Black-and-white versions of the athletics logos are available for occasions when use of color is not an option.

APPROPRIATE USE

The Hendrix Warriors wordmark and the athletics shield may only be used to identify Hendrix Athletics. The logo may not be combined with any other feature — including, but not limited to, other logos, words, graphics, or symbols. The shape, proportion, or color of the athletics logo may not be altered in any way. The logo may not be redrawn or altered (See fig. 3.3).

To ensure legibility, the school-leading athletics logo should never be reproduced at sizes smaller than 1 inch wide. Do not condense or extend the logo (See fig. 3.4).

When in doubt about the appropriate use of the athletics logos, contact the Office of Communications for assistance.

CONTROL AREA

As with the College’s logo, the Hendrix Warriors school-leading logo requires an open area around it for visual effectiveness. This open area is called “the Control Area” in this manual. No other visual elements may appear in the Control Area. The Control Area is a border (margin) of empty space around the logo equal to the width of the letter H in the Hendrix wordmark.



fig. 3.1 - Hendrix Warriors Logo



fig. 3.2 - Athletics Shield

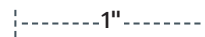

fig. 3.3 - Recreating the logo



fig. 3.4 - Limitations on size and proportion

minimum size for printing



This gray border the width of the “H” in “Hendrix” indicates the size of the Control Area around the logo. No words or images should be positioned closer to the logo than the Control Area’s outer edge.

VARIATIONS OF LOGO

Variations of the Hendrix Warriors logos have been created to fulfill almost any situation's needs. Contact the Office of Communications or the Department of Intercollegiate Athletics for assistance in determining when it's appropriate to use a variation of the logo. **Do not attempt to recreate any of these designs; art may be obtained from the Office of Communications, Department of Intercollegiate Athletics, or online at www.hendrix.edu/brandguide.**



INDIVIDUAL SPORT VARIATIONS

To be used in place of the Hendrix Warriors logo when referring to a specific sport rather than the entire athletics program, these variations replace "Warriors" with the name of the appropriate sport.



HENDRIX WARRIORS HORIZONTAL LOGO

To be used in situations where vertical space is limited. Control Area similar to the primary logo is recommended.



INDIVIDUAL SPORT HORIZONTAL VARIATION



HENDRIX WARRIORS WORDMARK

To be used in situations where vertical space is limited or where clarity or size is an issue.



INDIVIDUAL SPORT WORDMARK VARIATIONS

- a)
- b)
- c)



ATHLETICS SHIELD

To be used in situations where the production process cannot accurately reproduce the full Hendrix Warriors logo.



ATHLETICS "H"

Taken from the H shield. Primarily for use on athletics apparel.

WARRIORS WORDMARK ALTERNATIVE TO LOGO

To be used in situations where vertical space is limited or where clarity or size is an issue. The all-black and all-orange version of the Warriors wordmark without outlines can be reproduced at very small sizes.

LEGIBILITY

Clarity and readability are key to the overall strength of the Hendrix Warriors logo. Do not place the logo on colored or patterned backgrounds that impair the readability of the mark. Colored backgrounds are acceptable; however, it is important to use care in selecting the correct version of the logo to use in these situations (see **fig. 3.5**).

In situations where the logo is used on a color of similar value, the logo should be reversed (white) from the color. Or, if there is enough contrast, it can be printed in black.

Always take care in the placement of the logo and avoid busy or highly patterned backgrounds.

For assistance in selecting the appropriate version of the Warriors logo to use, contact the Office of Communications or the Department of Intercollegiate Athletics.

fig. 3.5 - Coordinating logo and background



COLORS

PMS 158

Orange and black have been the Hendrix colors for more than a century. To create consistency, a specific orange has been selected for the use as the Hendrix Orange: PANTONE MATCHING SYSTEM® 158 (See fig. 3.6).

BLACK

WHITE

Because Hendrix Orange is an integral part of the Hendrix College graphic identity, it is important to have the Hendrix Warriors logo appear in this color as often as possible. When the production method will not permit the use of the spot color, allowable alternatives are: A process color

equivalent for use when printing in CMYK: 0, 61, 97, 0 (See fig. 3.7). For on screen reproduction, use RGB values of 245, 130, 42 for use when displaying Hendrix Orange digitally on screen (See fig. 3.8).

Separate files have been created for PMS, CMYK, Black, Orange, and White. These files may be obtained from the Office of Communications or online at www.hendrix.edu/brandguide.

When presented on an orange or black shield, the H in the Warriors logo must appear in white. The only time the H should be “knocked out” to reveal the color behind the logo is when the shield itself appears in white.

ATHLETICS SHIELD

The athletics shield should only ever be black and orange, solid orange, solid black, or solid white, depending on the background. Black and orange is preferred wherever possible (fig. 3.9).

PRINTING IN BLACK AND WHITE

There may be instances when color is not an option, such as a newspaper advertisement or printing from a desktop laser printer. Black-and-white versions of the logo have been developed for use on these occasions. Do not print the color version of the logo in black and white.



fig. 3.6 - spot colors for offset printing



fig. 3.7 - 4-color process colors for offset printing



fig. 3.8 - RGB process for screens & projectors



fig. 3.9 - Athletics shield color variations



NOTE: The colors depicted on this page and throughout the Hendrix College Brand Guide are only representational of the actual PMS colors. Please refer to a PMS color guide for accurate color.

Athletics Logo

SYMBOL-LEADING

The Hendrix Warriors symbol-leading logo consists of two parts: the Warriors symbol (a helmet) and the Hendrix Warriors wordmark (fig. 4.1).

The symbol-leading athletics logo — the Warriors symbol (a helmet) and the Hendrix Warriors wordmark (see figs. 4.1 and 4.2) — should not be used in place of the Hendrix shield or in coordination with the Hendrix College logo. They should serve as unique symbols for the College’s athletics teams. **Do not attempt to recreate or modify these logos; art may be obtained from the Office of Communications, the Department of Intercollegiate Athletics or online at www.hendrix.edu/brandguide.**

Black and white versions of the athletics logos are available for occasions when use of color is not an option.

APPROPRIATE USE

The Hendrix Warriors wordmark and the Warrior helmet may only be used to identify Hendrix Athletics. The logo may not be combined with any other feature — including, but not limited to, other logos, words, graphics, or symbols. The shape, proportion, or color of the athletics logo may not be altered in any way. The logo may not be redrawn or altered (See fig. 4.3).

To ensure legibility, the athletics logo should never be reproduced at sizes smaller than 1.5 inches wide. Do not condense or extend the logo (See fig. 4.4).

When in doubt about the appropriate use of the athletics logos, contact the Office of Communications for assistance.

CONTROL AREA

As with the College’s logo, the Hendrix Warriors symbol-leading logo requires an open area around it for visual effectiveness. This open area is called “the Control Area” in this manual. No other visual elements may appear in the Control Area. The Control Area is a border (margin) of empty space around the logo equal to the width of the letter H in the Hendrix wordmark.



BRAND GUIDE

fig. 4.1 - Hendrix Warriors helmet
Full color logo



fig. 4.2 - Warrior helmet
Symbol only



fig. 4.3 - Recreating the logo



fig. 4.4 - Limitations on size
and proportion



This gray border the width of the “H” in “Hendrix” indicates the size of the Control Area around the logo. No words or images should be positioned closer to the logo than the Control Area’s outer edge.

VARIATIONS OF LOGO

Variations of the Warriors logos have been created to fulfill almost any situation's needs. Contact the Office of Communications or the Department of Intercollegiate Athletics for assistance in determining when it's appropriate to use a variation of the logo. **Do not attempt to recreate any of these designs; art may be obtained from the Office of Communications, Department of Intercollegiate Athletics, or online at www.hendrix.edu/brandguide.**



HENDRIX WARRIORS HORIZONTAL LOGO

To be used in situations where vertical space is limited. Control Area similar to the primary logo is recommended.



HENDRIX COLLEGE WARRIORS HORIZONTAL LOGO

To be used in situations where vertical space is limited. Control Area similar to the primary logo is recommended.



WARRIORS

HELMET REPLACES "O" LOGO OPTION

Can be used with or without "Hendrix College."
One-color options are also available.



HENDRIX
BASEBALL

INDIVIDUAL SPORT VARIATIONS

To be used in place of the Hendrix Warriors logo when referring to a specific sport rather than the entire athletics program, these variations replace "Warriors" with the name of the appropriate sport.



INDIVIDUAL SPORT HORIZONTAL VARIATIONS



HENDRIX COLLEGE WARRIORS

HELMET REPLACES "O" IN WARRIORS LOGO OPTION



WARRIORS INDIVIDUAL SPORT

HELMET REPLACES "O" LOGO OPTION

One-color options are also available.

LEGIBILITY

Clarity and readability are key to the overall strength of the Warriors Hendrix College logo. Do not place the logo on colored or patterned backgrounds that impair the readability of the mark. Colored backgrounds are acceptable; however, it is important to use care in selecting the correct version of the logo to use in these situations (see **fig. 4.5**).

In situations where the logo is used on a color of similar value, the logo should be reversed (white) from the color. Or, if there is enough contrast, it can be printed in black.

Always take care in the placement of the logo and avoid busy or highly patterned backgrounds.

For assistance in selecting the appropriate version of the Warriors logo to use, contact the Office of Communications or the Department of Intercollegiate Athletics.

fig. 4.5 - Coordinating logo and background



COLORS

PMS 158

Orange and black have been the Hendrix colors for more than a century. To create consistency, a specific orange has been selected for the use as the Hendrix Orange: PANTONE MATCHING SYSTEM® 158 (See **fig. 4.6**).

BLACK

WHITE

Because Hendrix Orange is an integral part of the Hendrix College graphic identity, it is important to have the Hendrix Warriors logo appear in this color as often as possible. When the production method will not permit the use of the spot

color, allowable alternatives are: A process color equivalent for use when printing in CMYK: 0, 61, 97, 0 (See **fig. 4.7**). For on screen reproduction, use RGB values of 245, 130, 42 for use when displaying Hendrix Orange digitally on screen (See **fig. 4.8**).

Separate files have been created for PMS, CMYK, Black, Orange, and White. These files may be obtained from the Office of Communications or online at www.hendrix.edu/brandguide.

WARRIOR HELMET

The Warrior helmet should only ever be black and orange, solid orange, solid black, or solid white, depending on the background. Black and orange (full color) is preferred wherever possible (**fig. 4.9**).

PRINTING IN BLACK AND WHITE

There may be instances when color is not an option, such as a newspaper advertisement or printing from a desktop laser printer. Black-and-white versions of the logo have been developed for use on these occasions. Do not print the color version of the logo in black and white.



NOTE: The colors depicted on this page and throughout the Hendrix College Brand Guide are only representational of the actual PMS colors. Please refer to a PMS color guide for accurate color.

fig. 4.6 - spot colors for offset printing



fig. 4.7 - 4-color process colors for offset printing



fig. 4.8 - RGB process for screens & projectors



fig. 4.9 - Warrior helmet color variations



Our Typefaces

A consistent approach to typography reinforces the effectiveness of the Hendrix College graphic identity. With consistent use, these typefaces will create a strong and recognizable identity for Hendrix College.

To provide flexibility and complement the Hendrix logo, two groups of typefaces have been selected for the use in the Hendrix College graphic identity. Group 1 is for documents such as memos, letters, and flyers created by the general population of Hendrix College. Group 2 is for use in documents that are being created by communication professionals such as offset-printed brochures or posters. A serif and a sans-serif typeface have been selected for each grouping.

GROUP 1

The typefaces selected for this group complement the typography used in the logo and are available on most PCs. If your PC does not have these typefaces, contact Technology Services and they will provide you with the typefaces. The serif face selected is Adobe Garamond Pro, and the sans-serif face is Trebuchet MS. These are TrueType fonts; while they are ideal for desktop purposes, TrueType fonts are not for use in commercial printing.

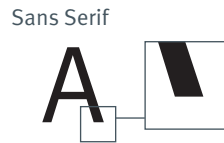

Trebuchet MS

ABCDEFGHIJKLMN
OPQRSTUVWXYZ
abcdefghijklmnopqrstuvwxyz
1234567890\$?!%&

Adobe Garamond Pro

ABCDEFGHIJKLMN
OPQRSTUVWXYZ
abcdefghijklmnopqrstuvwxyz
1234567890\$?!%&

GROUP 2

The typefaces selected for this group are for use by communication professionals. These typefaces are OpenType typefaces and are ideal for use in commercial printing. The serif type family selected is Calluna, and the sans-serif type family is Meta Pro Normal.

Meta Pro

ABCDEFGHIJKLMN
OPQRSTUVWXYZ
abcdefghijklmnopqrstuvwxyz
234567890\$?!%&

TYPOGRAPHIC STYLE

We use oldstyle numerals a fair amount in running text to mirror the oldstyle 1876 in our logo, but we don't recommend them for dollar amounts or when presenting facts and figures.

Calluna

ABCDEFGHIJKLMN
OPQRSTUVWXYZ
abcdefghijklmnopqrstuvwxyz
1234567890\$?!%&

Don't use Title Case (also known as Initial Caps) with small caps or all caps words.

THE TAGLINE FONT: MUSEO

Museo is a new typeface which captures some of the unique attributes of Hendrix College. In order for the tagline to not lose its visual distinctiveness, Museo should be used sparingly. We recommend constraining its use to the title/cover of documents, pull quotes, and occasionally facts & figures which need highlighting. It should never be used for typesetting large amounts of body copy.

Museo

ABCDEFGHIJKLMN
OPQRSTUVWXYZ
abcdefghijklmnopqrstuvwxyz
1234567890\$?!%&

BRAND GUIDE

Stationery

Stationery is the most visible and prominent representative of Hendrix College. Stationery includes business cards, letterhead, note cards, and envelopes. As part of the objectives of the Hendrix College Brand Guide, all stationery must have the same appearance. The look of the Hendrix stationery is based on a system of color, typefaces, type positions, and margins. Additionally, most stationery is printed on special stock approved by the College.

HOW TO ORDER STATIONERY ITEMS

The Business Office maintains a supply of stationery and envelopes. Contact Cris Williamson to “check out” what you need. Your office budget will be charged for the stationery you check out. To control costs, stationery is ordered in bulk once a year, with the Business Office managing the distribution.

NOTE: Taglines, slogans, promotional information, and all other extraneous information not addressed in these standards is prohibited from all stationery items. When in doubt about the appropriate use of text or images not included in these standards, contact the Office of Communications for assistance.

ENVELOPE

The #10 envelope (fig. 4.1) is the standard envelope used by the College along with its letterhead. On those occasions when a different envelope size is required, or when an office or department name is needed in the return address, contact the Office of Communications for assistance.

INVITATIONS

Invitation envelopes (the A-schedule) follow the #10 standard in figs. 5.1 & 5.2 with the option of centering the return address under the logo on the back flap. It is your choice to use one or two colors. Office name is also optional.

fig. 5.1 - #10 Envelope (not shown to scale; actual size 9.5 x 4.125 inches)

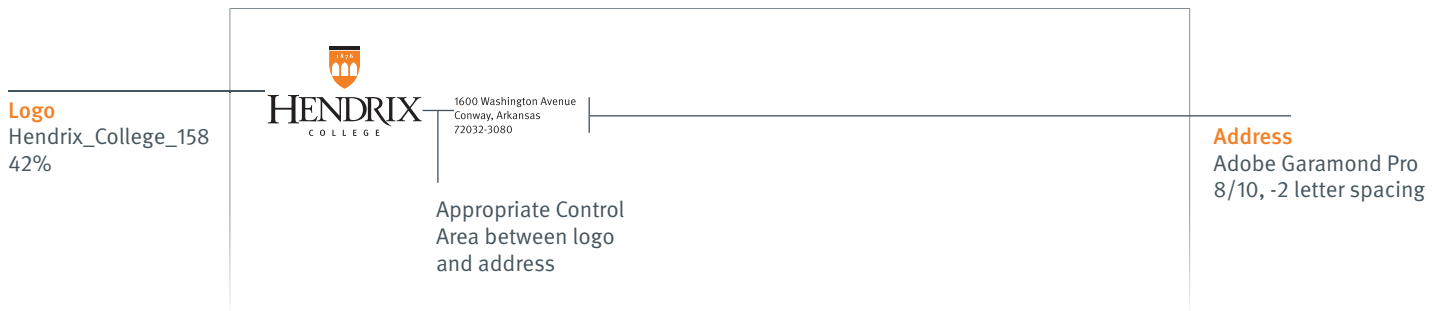
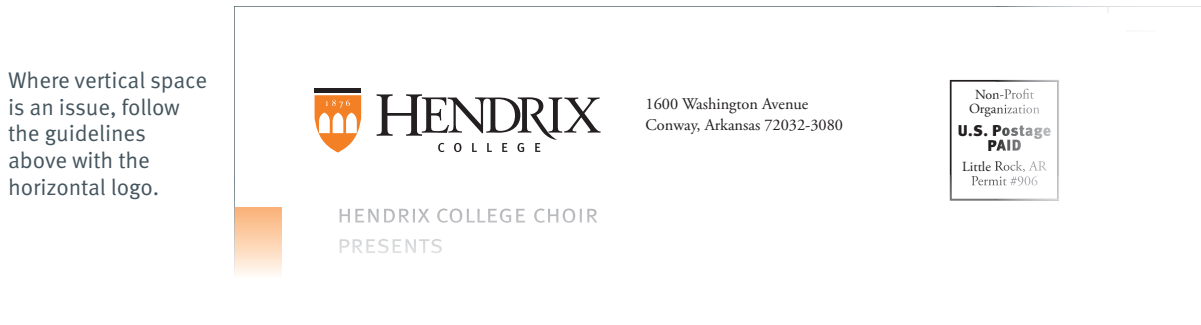
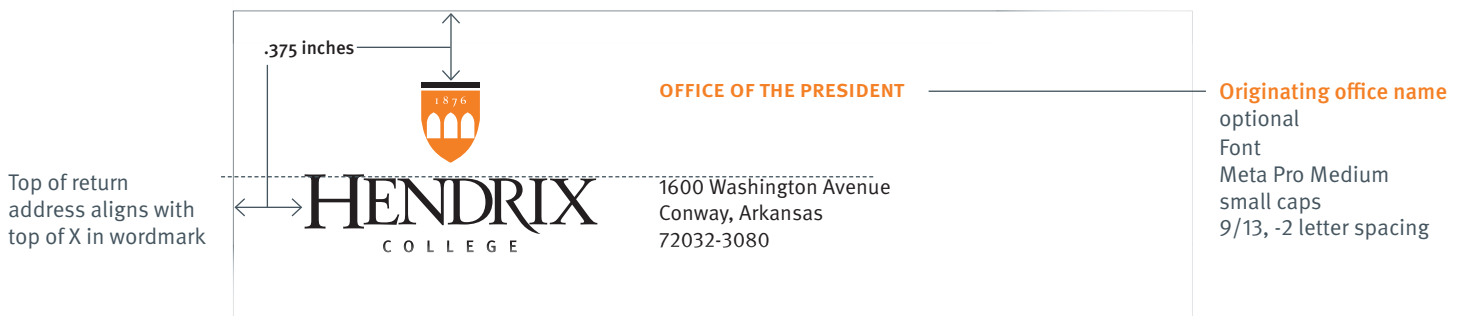

fig. 5.2 Return Address Portion of #10 Envelope (actual size)



Interior Signs and Exterior Plaques

INTERIOR SIGNS

Interior signs in new buildings will follow the typeface selections established in the Dawkins Welcome Center:

- › Room numbers for offices, meeting rooms, etc.: **Palatino** (fig. 6.1)
- › Employee names and titles: **High Tower Text** (fig. 6.2)
- › Room numbers and labeling for utility spaces (e.g., electrical closets): **GillSans ALL CAPS** (fig. 6.3)
- › Donor recognition plaques: **High Tower Text** (fig. 6.4)

EXTERIOR PLAQUES

New plaques affixed to buildings or monuments on campus will use High Tower Text as the typeface.

fig. 6.1
Palatino

289

fig. 6.2
High Tower

Sharron Russell

fig. 6.3
GillSans

101
ELECTRICAL

fig. 6.4
High Tower

The catering kitchen is
given by
Nancy May Fomby '69
and
Tom Fomby '69

Palatino

ABCDEFGHIJKLMN
OPQRSTUVWXYZ
abcdefghijklmnopqrstuvwxyz
1234567890\$?!%&

High Tower Text

ABCDEFGHIJKLMN
OPQRSTUVWXYZ
abcdefghijklmnopqrstuvwxyz
1234567890\$?!%&

GillSans (ALL CAPS)

ABCDEFGHIJKLMN
OPQRSTUVWXYZ

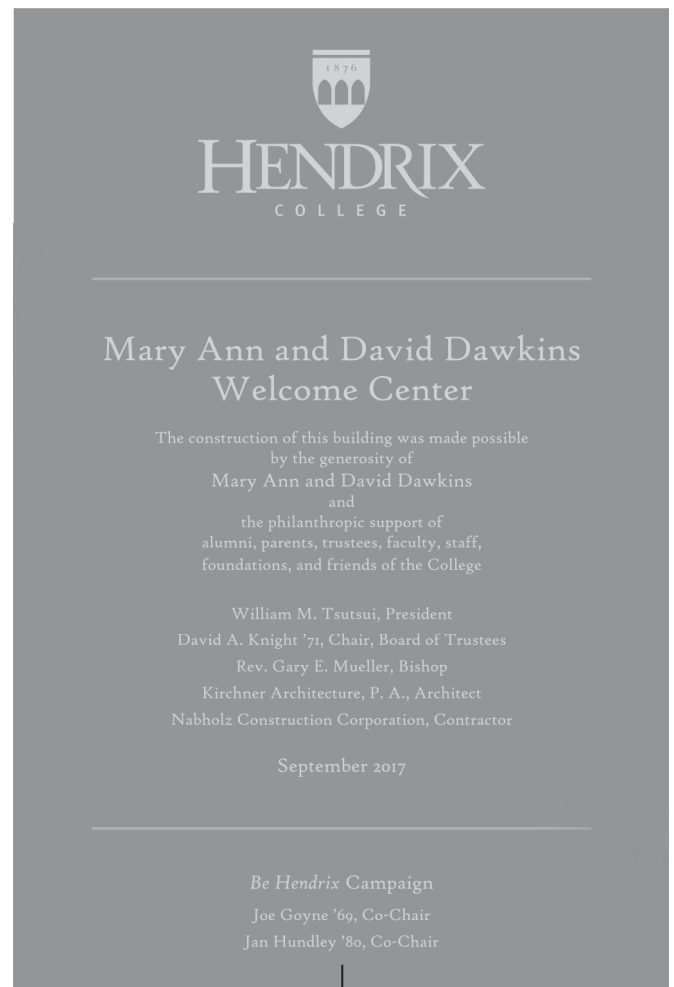
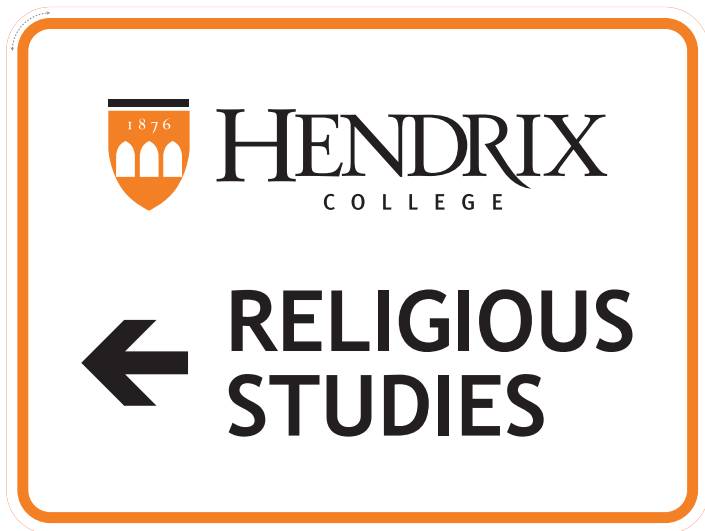

fig. 6.4
High Tower Text

Exterior Signs

- › Font: **Trebuchet** (mostly bold)
- › Colors: **Black & PMS 158 (CMYK: 0,61,97,0)**
- › Arrow Set: **Wingdings Font**
- › Base width: **12" Height**
(may vary depending on needs of design)



24" x 18"

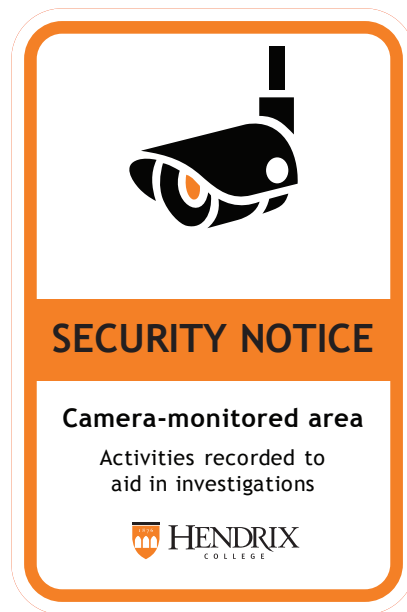

12" x 18"



12" x 15"



18" x 24"

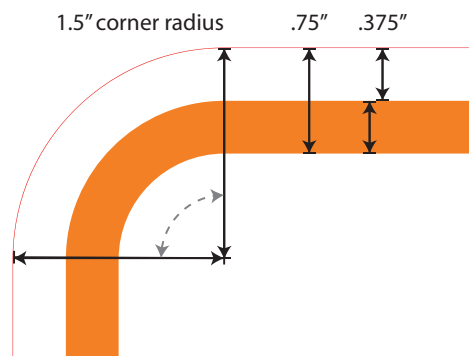

Interior/Exterior Informal Signage

From time to time, offices or departments have a need for less formal signs. They may be printed off and used inside or outside a building for a specific purpose or occasion.

› Informal signs may use typefaces from Group 1 (Trebuchet MS/ Adobe Garamond Pro) or Group 2 (Meta Pro/Calluna). See page 11 of this guide for details.

› **Colors:** Black & PMS 158 (CMYK: 0,61,97,0)

› **Arrow Set:** Windings Font

The examples below have been printed from color copiers and placed in holders or frames at specific indoor locations on campus. For short-term outdoor display, paper signs following this format may be slipped into sheet protectors and posted on windows or doors.



Frequently Asked Questions

About the Hendrix Brand and Graphic Identity

Can I use a Hendrix logo for a poster that I'm creating for my department?

Members of the Hendrix community are authorized to use Hendrix imagery to identify and promote Hendrix-sponsored activities and projects, following the standards outlined in the Brand Guide.

Communications staff members are happy to review material prepared by Hendrix community members for compliance with our brand standards, on request, and to work with community members to select the best version of Hendrix logos and brand identity components for their individual projects.

Why can't I print the Hendrix logo in purple? It looks really good in my design.

We like purple too – and we're sure your design looks really great with a purple logo. However, what we like personally has no bearing on how we decide to use Hendrix imagery. Consistency is the key to establishing our graphic identity in the minds of our audience. We must be picky and precise in how we present Hendrix to the world to ensure that Hendrix images are always the same. Coca-Cola and McDonalds burn their logos into our collective brains by doing it almost the same way every time – you'll never, ever see the golden arches in purple! So, the logo of Hendrix may be printed only in the College's official colors: black or orange (PMS 158) – or in white (the absence of color).

None of the Hendrix logos or images I've found online work for what I want to do. Can I use just part of a logo or move the parts around so that it looks better to me?

Any deviation from these established standards must be approved by the Vice President of Communications. Warning: Because consistent use of our imagery is so important to establishing our graphic identity in our audiences' minds, we're pretty hard to convince. If you have problems working with Hendrix imagery, just let us know. Our designers are creative people who may have already come up with a solution for your problem and, if so, we're happy to share.

I want to follow the rules, really I do ... but I'm confused. Who can help me?

Contact Amy Forbus in the Communications Office (ext. 1462 or forbus@hendrix.edu), explain your situation, and we will figure out how best to help you.

If you have a quick question, we may be able to connect you with someone who can answer that question for you immediately or get back to you quickly.

If your graphic identity questions are more in-depth, we'll schedule a consultation with you as soon as we can. Please keep in mind that our staff is as busy as you are, so it may take a few days – or even a couple weeks – to find a time that works for you and for our production schedule.

If you want to work with Communications to ensure consistency with the College brand and graphic identity, use the Project Request Form at www.hendrix.edu/communications/projectrequestform, then attach supporting materials. Whether you need a banner, brochure, envelope, invitation, poster, program, sign, or something else to look appropriately Hendrixy, it's the place to get started. (Please remember, though, that some projects require a few weeks of lead time. If we can't do it by your deadline, we'll let you know as soon as we can.)

How do I order stationery, business cards, nametags?

Ordering these basic supplies is spread through three different offices.

STATIONERY: The Business Office maintains a supply of stationery and envelopes. Contact Cris Williamson to “check out” what you need. Your office budget will be charged for the stationery you check out. To control costs, stationery is ordered in bulk once a year, with the Business Office managing the distribution.

BUSINESS CARDS: Human Resources orders business cards two or three times each year, generally near the start of each term and sometimes during the summer. They group orders together to control costs. Cards must be ordered in multiples of 250, which is the smallest number that can be ordered at one time. If you have special needs between group orders, contact Human Resources. They are happy to place your order, but they want you to be aware that the cost of the cards will be almost double what you would pay as part of a group order. Your office budget will be charged for business cards.

NAMETAGS: Human Resources handles nametag orders for newly hired staff members and, on request, for those who need replacements. Your office budget will be charged for nametags.

I want to order a cake with the Hendrix logo on it for my grandson's high school graduation party. My baker won't put your logo on the cake without your permission. How do I get permission?

Call, send an email, or write a letter to the Office of Communications explaining what you need. Permission to use the Hendrix logo for gift and personal-use items is generally granted, providing the request comes from a Hendrix alumnus/alum, parent, or friend of the College, and the individuals and vendors involved agree to follow our graphic identity standards. We will also consider the type, quality, and life-span of the item to be produced before granting permission. (So, if you promise to eat the whole cake to destroy the evidence, we won't be too picky about how faithfully the baker reproduces our logo.)

Permission will be granted for one-time use only, and the Office of Communications may ask to review proofs of the products or material before production begins to ensure standards are met (this does not apply to cakes, unless you invite us to the party).

To request one-time, non-commercial use, contact the Office of Communications in writing (preferably by email), detailing the request and naming the vendor who will produce the final product. If the request is approved, the Vice President for Communications will provide written approval and the appropriate imagery to the vendor.

I need to order merchandise from an off-campus vendor who says he needs written permission from the College to use our logos. Why won't he just take my word for it that it's OK to use our logo, since I work for the College?

Your vendor is a very smart person. He knows, from working with other companies, that to ensure their imagery is used consistently most companies designate one person or office to approve all requests for use. At Hendrix, that office is the Office of Communications.

All external vendors using our imagery are required to follow Hendrix graphic identity standards, and the College reserves the right to refuse payment to any vendor that produces and delivers items that deviate from our standards. So, it's important to everyone that we do things right. To start the process, talk with us about how you plan to use the logo or other College imagery. We will make sure that you have the right artwork for the type of merchandise that you are ordering. We are happy to talk directly with the vendor to help move the project forward. We will supply the artwork to the vendor along with written permission to use the images for the purpose outlined. And, we will check the final proof or review a sample to make sure that all our standards are met.

I'm reordering shirts for our office. We've ordered them before. Can't I just go straight to the vendor and get more?

Communications doesn't need to be involved in every reorder – especially if you are making no changes to artwork that has been previously approved and are working with a vendor who has already received permission to use our artwork for this purpose. However, not every item that has been used on campus for years meets our graphic identity standards. Unless you are 100% sure that your item is in perfect compliance with our standards, bring a sample of your last order by our office for a quick review. If there's a problem, we'll help you fix it. And if everything is perfect, you'll leave a few minutes later with our Graphic Identity Stamp of Approval. What could be better?

Brand, Design, & Editorial Standards

Consistent use of correct logos is just one way to enhance and protect the Hendrix College brand. Production values, content choices, and careful planning of images and language are equally important.

Any item that represents Hendrix should use the highest feasible production values that are appropriate for the target audience and project goals. Production values include professional design, images, and language.

Content for any project that represents Hendrix should be accurate, honest, informative, and inspiring and should support, in some manner, the College's Statement of Purpose, Statement on Diversity, Statement on Church Relatedness, Strategic Plan, or Vision for Student Learning.



HENDRIX
COLLEGE

1600 Washington Avenue › Conway, Arkansas 72032
www.hendrix.edu/marcom